

VISION

Cutting-creasing machine with sheets/fan fold cardboard

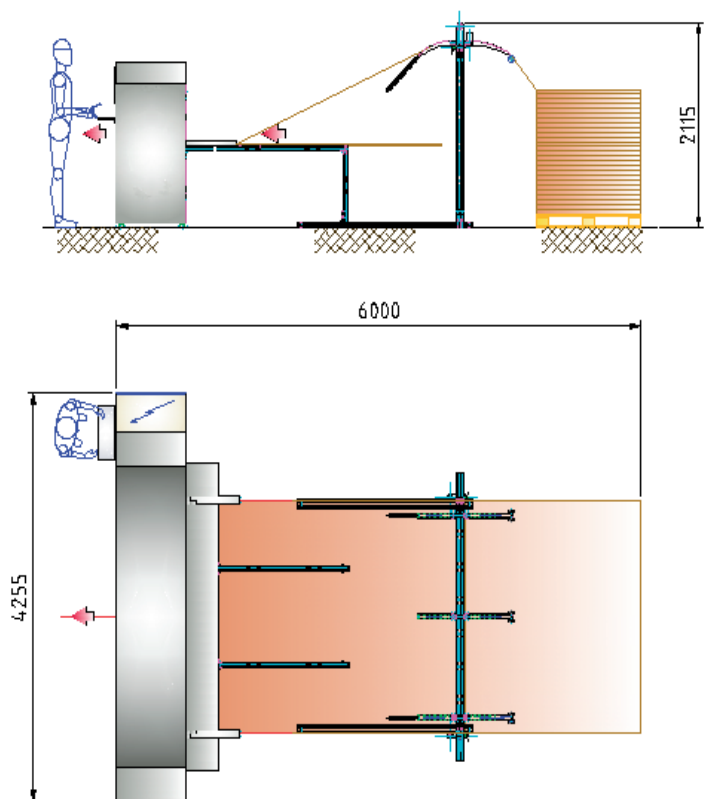

Longitudinal groups central configuration

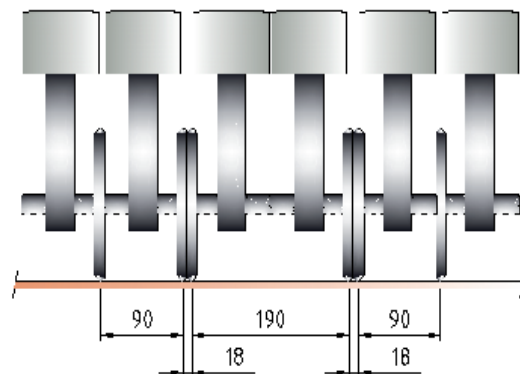

Longitudinal groups side configuration

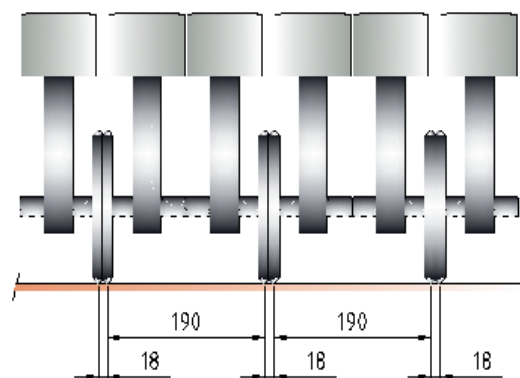

Technical features:

- installed power: 4 Kw.
- operating pressure: 6 bar.
- primary tension: 400 V a 50 Hz 3P+N+T.
- production: 7/8 boxes/min.
- groups positioning time from: 7 to 12 sec.
- max. cardboards width: 2800 mm.
- max. cardboards length: endless.
- single fan fold cardboard/sheets.
- cardboard types: A,B,C,K,BA,BC,EB mono/double wave.
- operator panel.
- thickness from 2 to 7 mm.

Optional:

- custom-made boxes: high/low resolution direct printing on the cardboard / "print&aply" labelling machine.
- creasing with perforation.
- slotting

- CAD/CAM system with box's library FEFCO/LCR.
- function to acquire production lists by uploading/downloading from Host (AS400, SAP, SQL).



LCR macchine automatiche srl

via del Lavoro 5, 40050 Castello D'Argile Bologna Italy

tel.: +39 051 976434 fax.: +39 051 976624

www.lcrgroup.it

sales@lcrgroup.it