

SEL CO PLAST WN 7

NUMERIC CONTROLLED PANEL
SIZING CENTRE

BOLSTERING PERFORMANCE



THE MARKET EXPECTS

a change in manufacturing processes that enables companies to accept the largest possible number of orders. This is coupled with the need to maintain high quality standards while offering product customisation with quick and defined delivery times, as well as responding to the needs of most automated companies.

BIESSE RESPONDS

with technological solutions which underline and support technical expertise, as well as process and material knowledge.

SELCO PLAST WN 7 is the result of continuous innovations aimed at increasing productivity and guaranteeing the overall quality of the machining operations. SELCO PLAST WN 7 is positioned at the top of the range of beam saws with one cutting line: high performance in reduced times, to meet the needs of medium and large furniture-making companies.



SELCO PLAST WN 7

- TOP CUTTING QUALITY
- MACHINING PRECISION
- QUICK, SIMPLE ADJUSTMENTS
- PROCESS OPTIMIZATION

TOP CUTTING QUALITY

The solid structure of the base guarantees consistent quality and reliability, thanks to the perfect machining stability.



Maximum quality finished products thanks to the air cushioned working surface of the machine body equipped with flat segments of anodised aluminium for the handling of delicate materials. In addition, this characteristic ensures the surface next to the blade is kept constantly clean.



The optimum balancing and weight distribution on the two guides ensures the total absence of vibrations and perfectly straight cuts.

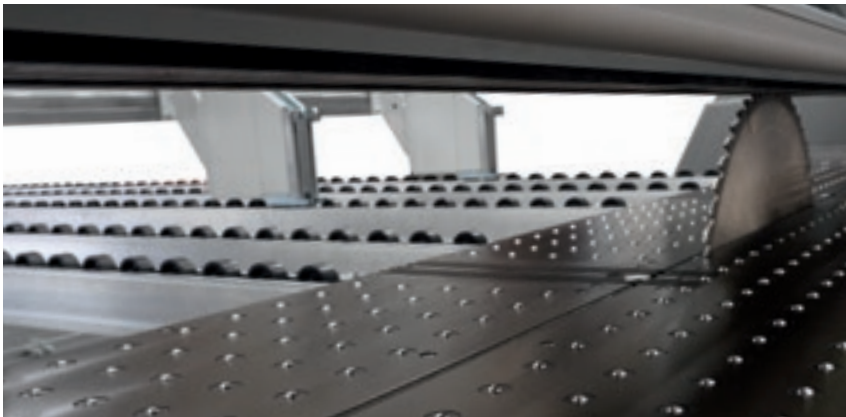
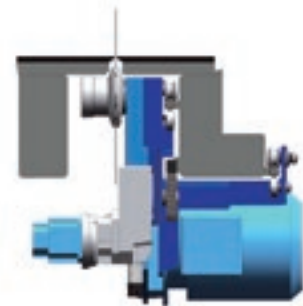

The anti-slide device controls the blade position and number of rotations, intervening to adjust the advance speed. **Maximum cutting quality, a longer blade lifespan, and reduced maintenance costs.**



The motorised vertical blade adjustment ensures precise, quick adjustment of blade protrusion.

THE PRESSURE SYSTEMS HAVE AN EFFICIENT SUCTION SYSTEM THAT GUARANTEES THE CUTTING QUALITY, ENSURING THE AREA IS ALWAYS KEPT CLEAN DURING THE MACHINING OPERATION.



The double presser has a split, independent structure that ensures even, controlled pressure on the book of panels to be cut thanks to the absence of openings for the grippers. It creates a real airtight chamber for rough trim cuts, allowing the dust to be completely removed.



MACHINING PRECISION

The protrusion of the main blade and the opening of the presser are automatically adjusted by the numerical control on the basis of the thickness of the book to be cut, thereby obtaining the best cutting quality in all working conditions.

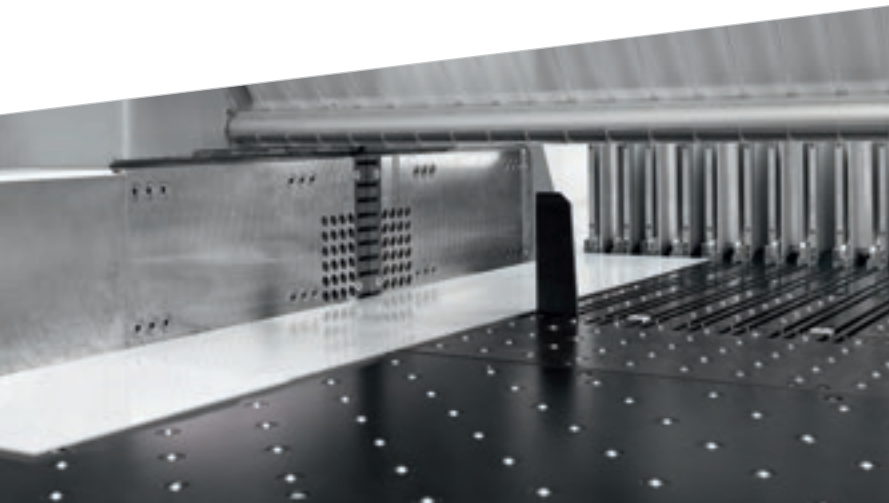

Thanks to the side aligners integrated in the blade carriage, perfect positioning is possible even with very thin and/or flexible panels, thereby minimising cycle times.

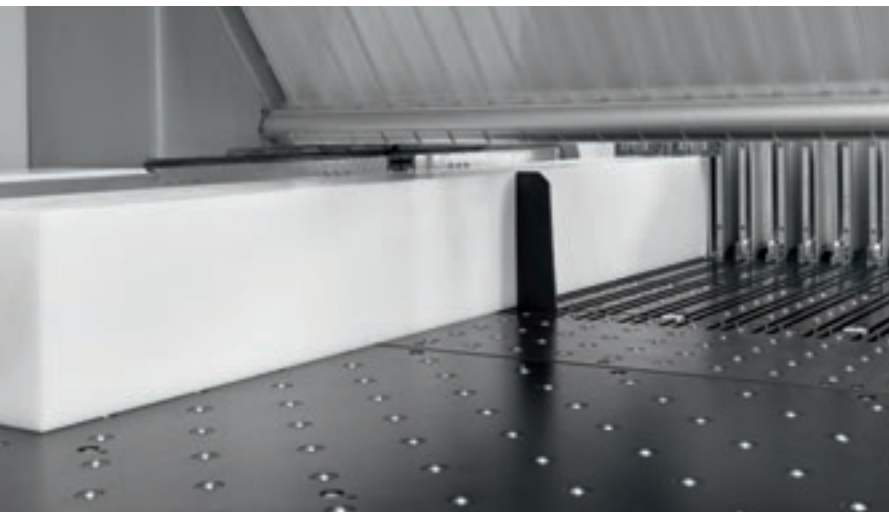

Cutting line closure system, to prevent the longitudinal trim cuts from falling into the machine and fouling the blade path.



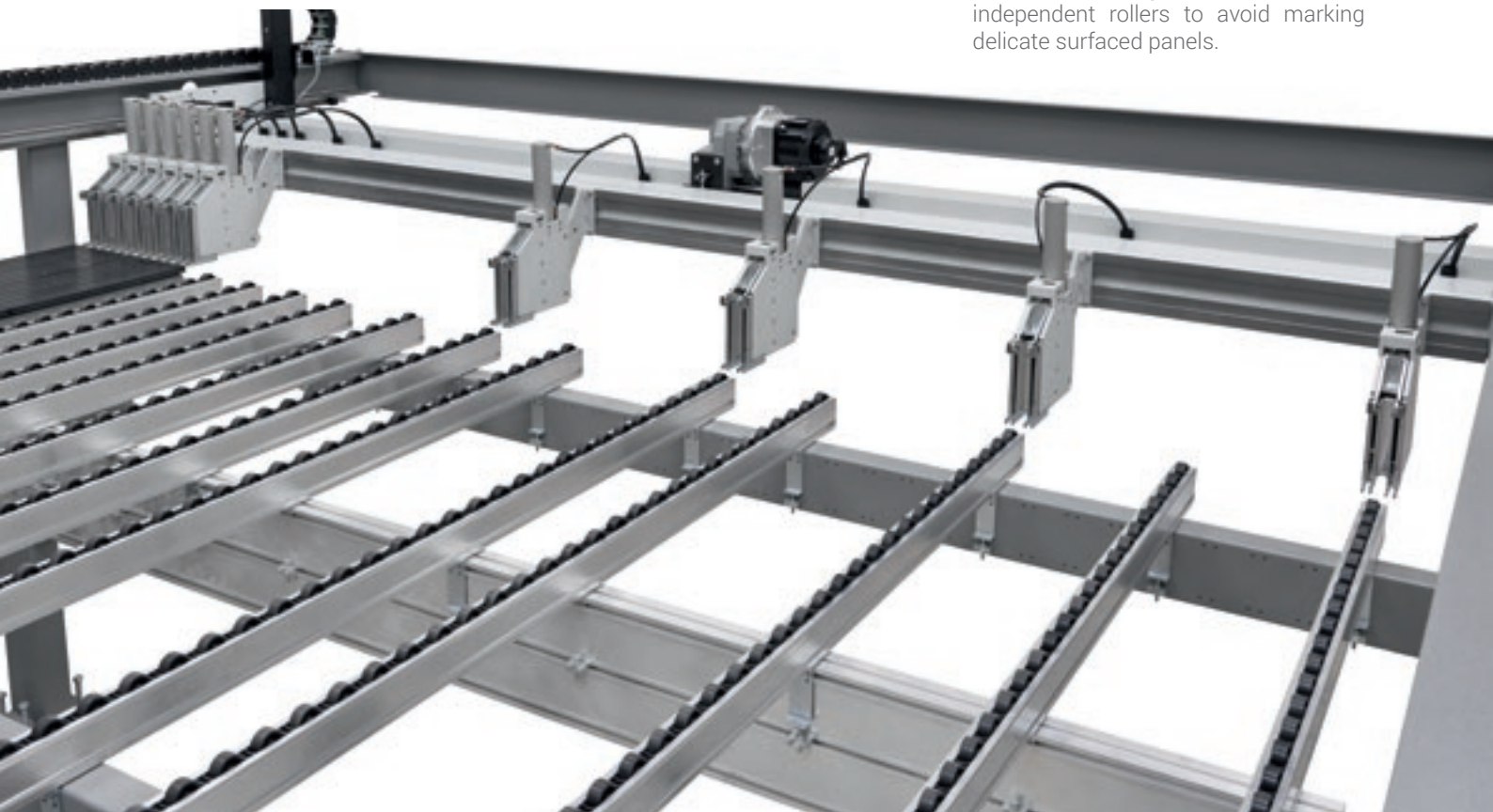

Fast, accurate positioning of the panels for optimum cutting precision, thanks to the robust pusher carriage activated by a brushless motor. The slide surface below the pushing device is fitted with independent rollers to avoid marking delicate surfaced panels.

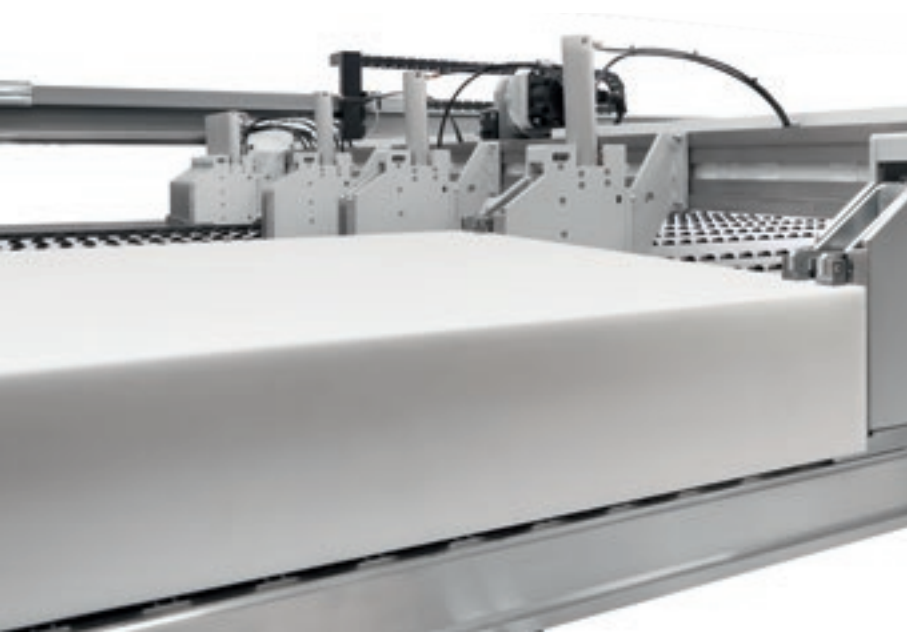

The **grippers** ensure the book is firmly secured. Their specific design and machine logic enable the full ejection of cut panels from the cutting line, making it easier for the operator to handle both panels and waste.

SELCO TECHNO LOGY

PRECISION CUTTING

Selco beam saws' cutting-edge technology responds to the needs of operators who process technological materials.

The robust pushing carriage driven by a brushless motor on hardened racks and cemented gear wheels, together with the magnetic band positioning control and component locking via independent grippers, guarantee the utmost cutting precision and quality for panels of various formats and sizes.

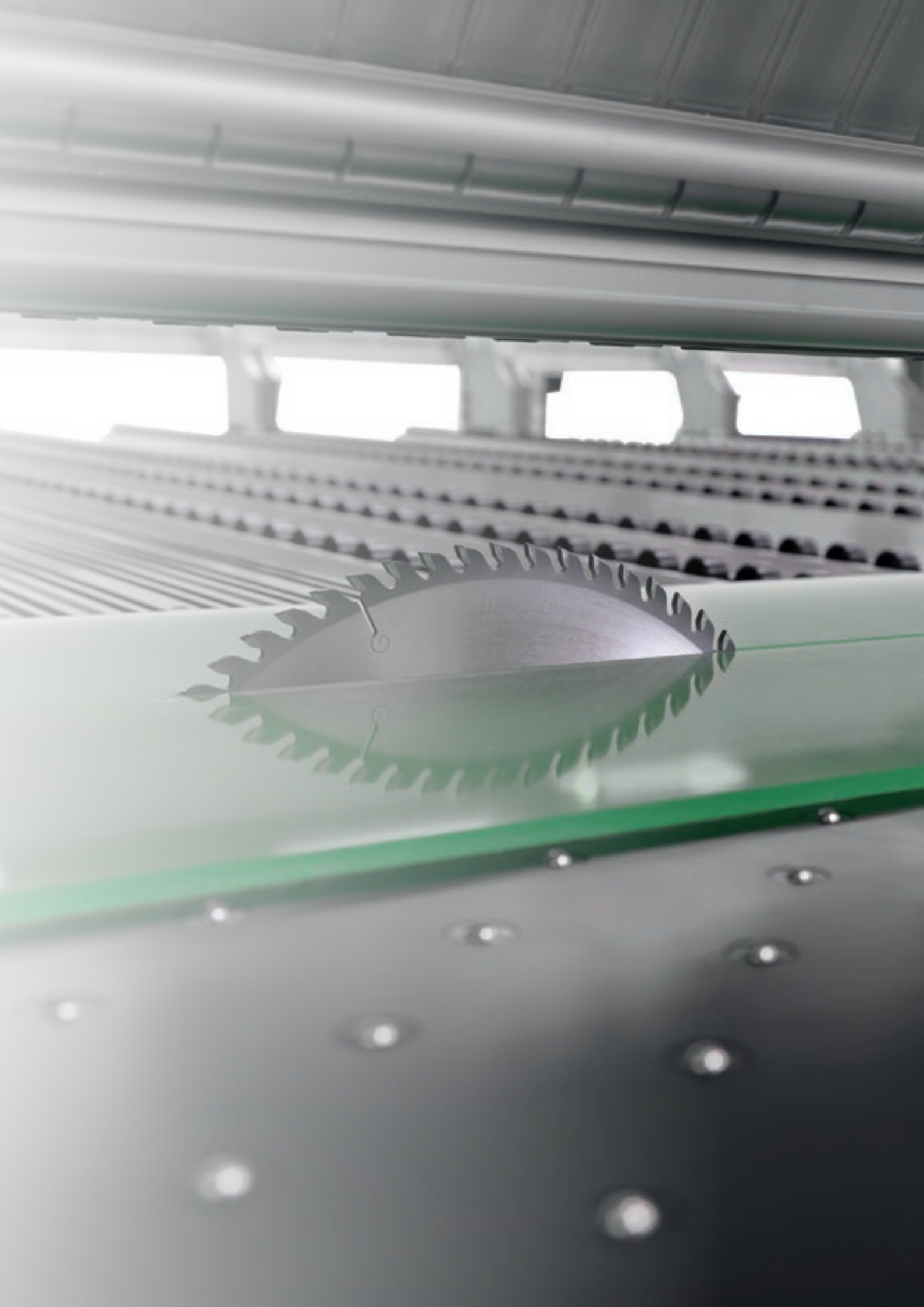

TOOLING IN JUST A FEW SECONDS

The “Quick change” system is the fastest, safest and most ergonomic device for replacing the blades without using tools.

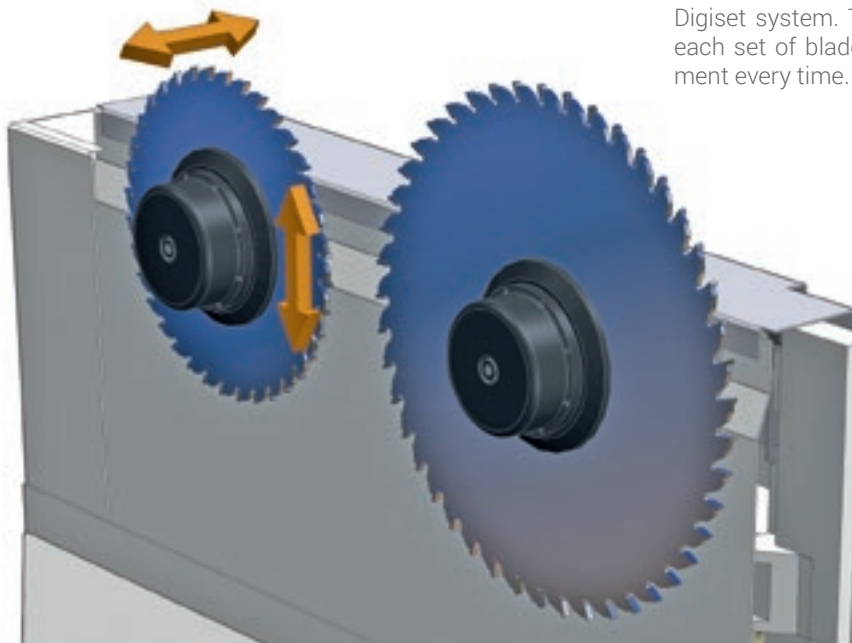

Fast, accurate setting of the scoring and main blades, using Digiset system. The system also stores the information for each set of blades, ensuring repeatable and accurate alignment every time.

EASY TO USE, WITH OPTIMISED MACHINING OPERATIONS

The OSI (Open Selco Interface) numerical control guarantees the management of the execution of cutting patterns, and optimizes all movements relative to controlled axis (i.e. Pusher and Saw Carriage, pressure beam, blade height). It ensures the blade protrudes from the book to the correct degree during sectioning, and calculates the most suitable cutting speed on the basis of the book height and trim cut width. It helps ensure the best cutting quality at all times.

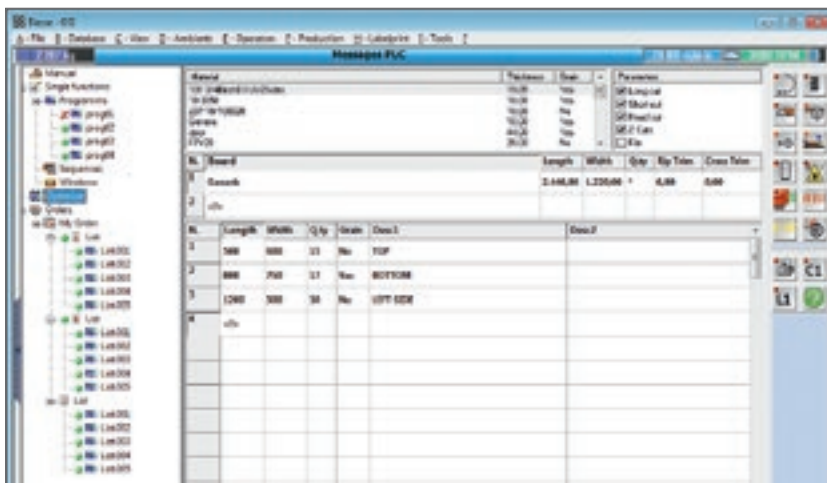

QUICKOPTI

Simple, intuitive software for optimising the cutting patterns directly on the machine.



LABELLING

A special software creates individual labels and prints them in real time, on the machine. The information available can also be printed in bar code form.

SOFTWARE FOR THE SMART, ASSISTED MANAGEMENT OF CUTTING PATTERNS



B_OPTI IS THE SOFTWARE FOR OPTIMISING CUTTING PATTERNS, DEVELOPED ENTIRELY BY BIESSE. BASED ON THE LIST OF PIECES TO BE PRODUCED AND THE PANELS AVAILABLE, IT CAN CALCULATE THE BEST SOLUTION TO MINIMISE MATERIAL CONSUMPTION, SECTIONING TIMES AND PRODUCTION COSTS.

- Simple, user-friendly interface.
- Excellent reliability of the calculation algorithms for production batches in small and large companies.
- Automatic import of the cutting list generated by the software for the design of furniture items and/or ERP management systems.





CUSTOMER CARE IS WHO WE ARE

SERVICES is a new experience for our customers, to offer not just excellent technology but the added value of an increasingly direct connection with the company, the professionals who work there and the experience they embody.



ADVANCED DIAGNOSTICS

Digital channels for remote interaction online 24/7. Always ready to intervene on-site seven days a week.



A WORLDWIDE NETWORK

39 branch offices, over 300 certified agents, retailers in 120 countries, and spare parts warehouses in America, Europe and the Far East.



SPARE PARTS AVAILABLE IMMEDIATELY

Identification, shipping and delivery of spare parts for every need.



EVOLVED TRAINING OPPORTUNITIES

Lots of on-site, online and classroom training modules for personalised growth.



VALUABLE SERVICES

A wide range of services and software packages to help our customers achieve continuous improvements in performance.

AN EXCELLENT LEVEL OF SERVICE

+550

HIGHLY SPECIALISED
TECHNICIANS AROUND
THE WORLD, READY TO HELP
CUSTOMERS WITH EVERY
NEED

90%

OF MACHINE DOWN CASES
WITH RESPONSE TIME
UNDER 1 HOUR

+100

EXPERTS IN DIRECT
CONTACT THROUGH
REMOTE CONNECTIONS
AND TELESERVICE

92%

OF SPARE PARTS ORDERS
FOR MACHINE DOWNTIME
PROCESSED WITHIN 24
HOURS

+50.000

ITEMS IN STOCK IN THE
SPARE PARTS WAREHOUSES

+5.000

PREVENTIVE MAINTENANCE
VISITS

80%

OF SUPPORT REQUESTS
SOLVED ONLINE

96%

OF SPARE PARTS ORDERS
DELIVERED IN FULL ON TIME

88%

OF CASES SOLVED WITH
THE FIRST ON-SITE VISIT

TECHNICAL SPECIFICATIONS

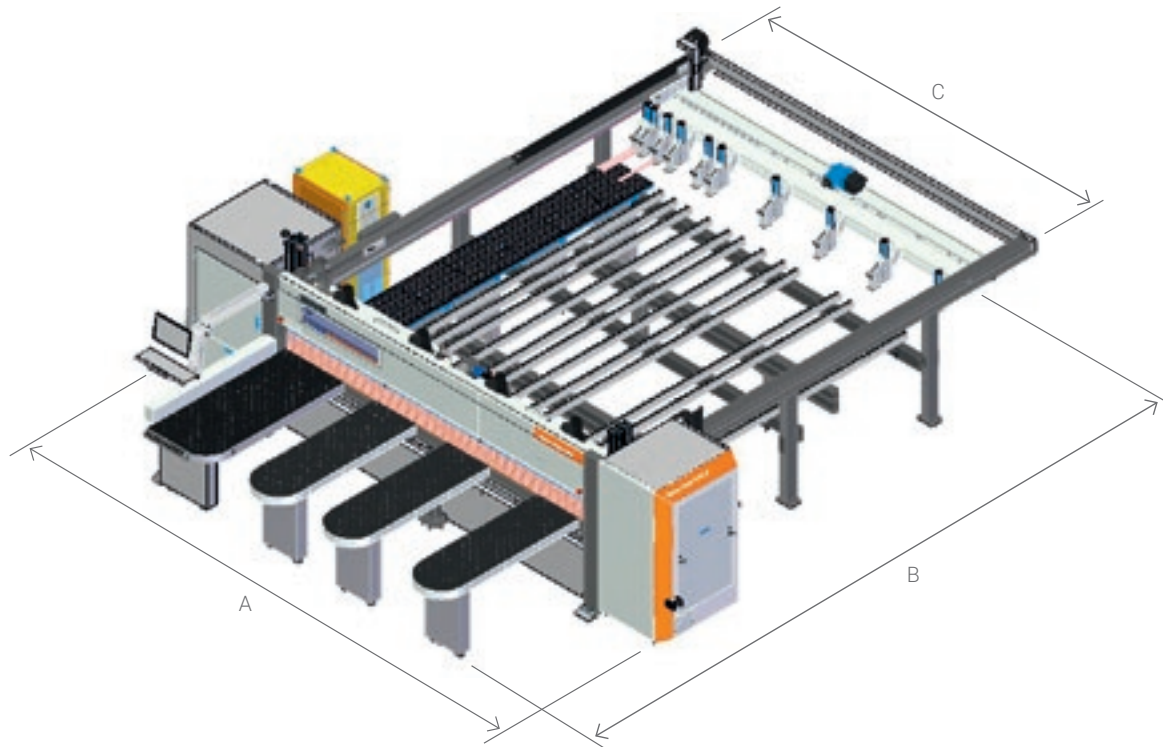

SELCO PLAST WN 750 - 770		4500 x 3200	4500 x 4500	6500 x 6500
A	mm/inch	7320/288	7320/288	9320/367
B	mm/inch	7180/283	8500/335	10500/413
C	mm/inch	5200/205	5200/205	7200/283

		750	770
Maximum blade protrusion	mm/inch	152/6	177/7
Main blade motor	kW	22	30
Blade carriage transfer		brushless	brushless
Blade carriage speed	m/min - ft/min	0 - 160 / 0 - 525	0 - 160 / 0 - 525
Pushing device transfer		brushless	brushless
Pushing device speed	m/min - ft/min	90/295	90/295

The technical specifications and drawings are non-binding. Some photos may show machines equipped with optional features. Biesse Spa reserves the right to carry out modifications without prior notice.

Equivalent sound pressure level in position in the work area during machining (LpA) dB(A) 82,76. Environmental correction factor (K) dB(A) 5,35. Sound power level during machining (LwA) dB(A) 106,14. Weighted peak instantaneous sound pressure in the work area during machining dB(C) < 130. Uncertainty of measurement K = 4 dB (A). The measurement was carried out in compliance with ISO 3746, ISO 11202. The noise levels indicated are output levels and do not necessarily represent safe operational levels. Even though there is a relation between emission levels and exposure levels, this cannot be used reliably to establish whether or not further precautions are necessary. The factors determining the actual noise levels to which the operative personnel are exposed to include the length of exposure, the characteristics of the work environment, other emission sources, i.e. the number of machines and machining operations in the vicinity. In any case, this information will help the machine user to better assess the danger and risks involved.

SOPHIA

GREATER VALUE FROM MACHINES

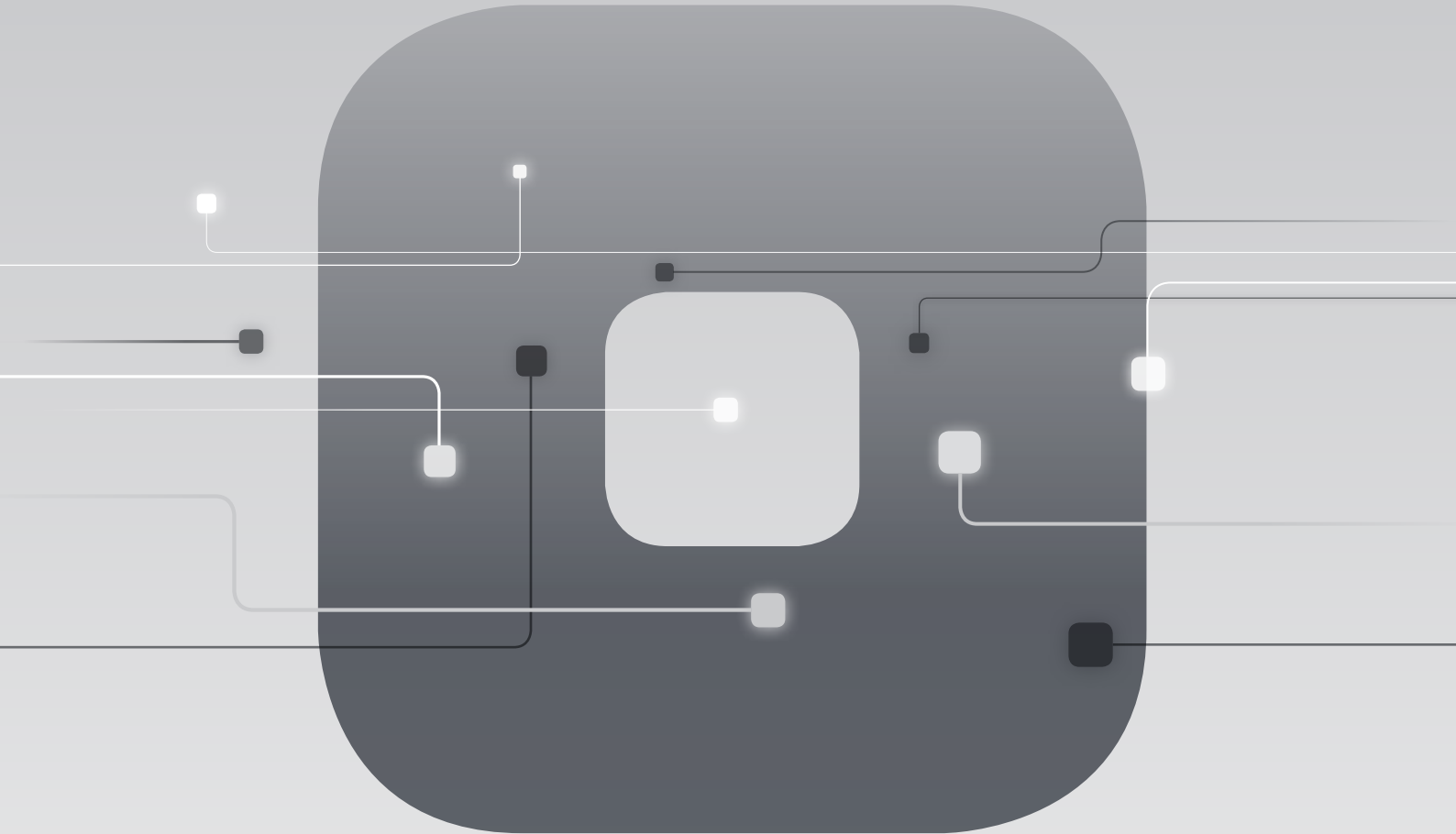

The Biesse IoT platform which enables customers to access an extensive range of services to streamline and rationalise their work management processes.

□ SERVICES

□ PROACTIVITY

□ ANALYSIS



in collaboration with **accenture**

MADE WITH BIESSE

BIESSE TECHNOLOGY AND CREATIVITY BY ACTION GIROMARI

Action Giromari is a creative workshop that has been working with laser branding and engraving for over 20 years. Developed at a time when globalisation and, to some extent, standardisation were hallmarks of the global culture and economy, the company offered the market a chance to preserve and strengthen the personal aesthetic of creatives, designers and companies.

The company stands out for its ability to work with any type of material.

"We don't develop a single category of products. Rather, thanks to the wide variety of materials we work with and the varied technologies we use, we are able to tailor any project, both for small scale and mass production. We develop stands, signs, branding products and anything that relates to visual communica-

tion. Other products include coverings, countertops and custom made interior design products for stores. We also work with several architects, who send us their designs. Our clients mainly ask us to design and create products that highlight their identity as a company to help them stand out on the market through creativity and design," Raffaele Bastianoni, the company owner, explains.

Action Giromari handles every phase of production itself, from prototyping to engineering to packaging, every single step is inspected first hand. Numerical control technology allows Action Giromari to cut, mill, score and shape each piece. The steps that follow (assembly, gluing...) all the way to final finishing, are exclusively carried out by hand.

"Biesse technology plays a key role in

allowing us to be more versatile and offer ad hoc solutions. Thanks to the new Rover Plast M5 purchased in May 2016 we have increased our production of complex shapes and 3D objects: unique products that have great value on the market. When we chose Biesse, an Italian company that offered reliability and know how, we weren't simply interested in the new numerical control milling cutter, rather we acquired a veritable partnership.

"We consider Biesse a strategic partner for Giromari's technological development" Bastianoni says in closing.



Founded in Italy,
international native.

We are an international company that manufactures integrated lines and machines to process wood, glass, stone, plastic and composite materials and what will come next.

Thanks to our rooted competence nurtured by an ever-growing worldwide network, we support your business evolution – empowering your imagination.

Master of materials, since 1969.

We simplify your
manufacturing
process to make
the potential of
any material
shine.



Join the
Biesse world.

[biesse.com](https://www.biesse.com)



